

ENERDYNE

Technologies, Inc.

Quality You Can See

MODEL DEC1000A136

COMPRESSED VIDEO DECODER

User Manual

**Document Part Number: SPDEC007
DEC1000A1360MAN**

Enerdyne Technologies, Inc.
1935 Cordell Court
El Cajon, CA 92020

Tel: 619-438-6000, Fax 619-438-6068

Toll-Free: 877-363-7396
www.enerdyne.com

Notice

The information contained in this document is subject to change without notice.

ENERDYNE TECHNOLOGIES, INC. MAKES NO WARRANTY OF ANY KIND WITH REGARD TO THIS MATERIAL, INCLUDING, BUT NOT LIMITED TO, THE IMPLIED WARRANTIES OF MERCHANTABILITY AND FITNESS FOR A PARTICULAR PURPOSE. Enerdyne Technologies, Inc. shall not be liable for errors contained herein or for consequential damages in connection with the furnishing, performance or use of this material.

This document contains proprietary information that is protected by copyright. All rights are reserved. No part of this document may be photocopied, reproduced or translated to another program language without the prior written consent of Enerdyne Technologies, Inc.

Copyright © 1999 Enerdyne Technologies, Inc.

ADVS[®] is a registered trademark of Enerdyne Technologies, Inc.

All rights reserved.

- Printing History -

First Edition -**SPDEC007**- September, 1996
Second Edition -**SPDEC007A**-November, 1998
Third Edition - **SPDEC007** - June 14, 1999
Revised -**DEC1000A136** – December 20, 2004

CONTENTS

CHAPTER 1 INTRODUCTION	1-1
About This Manual	1-1
Theory of Operation	1-2
DEC1000A136 Decoder Functional Description	1-2
DMUX1000 Data Demultiplexer.....	1-3
Typical Application.....	1-3
DEC1000A136 Specifications.....	1-6
CHAPTER 2 DECODER OPERATION	2-1
Series 1000 Decoding Equipment.....	2-1
Software Interface.....	2-1
Using the Software Interface.....	2-2
AUTO on/off	2-2
BAUD nn.....	2-2
BSF nn	2-2
DATE mm/dd/yy	2-3
DATEON yx.....	2-3
DEFAULT nn (GET nn).....	2-3
ERROR nn	2-4
ES nn.....	2-4
HELP or ?.....	2-4
HELP nn.....	2-4
ID nn	2-4
MINIBAR yx.....	2-5
PROMPT n . . . n.....	2-5
RELOAD.....	2-5
RESET (Z).....	2-5
S (STATUS).....	2-5
SAVESCREEN	2-5
TCOLOR rrggbb.....	2-5
TEST nn.....	2-5
TIME hh:mm:ss	2-6
TIMER nn.....	2-6
TTEST.....	2-6
V nn.....	2-6
VCLR.....	2-7
YC on/off.....	2-7

Option Commands 2-7
Demultiplexer Overview 2-7
Audio Data Rules 2-7
SS Data Rules 2-8
AS Data Rules 2-8

CHAPTER 3 INSTALLATION AND MAINTENANCE PROCEDURES..... 3-1

Introduction..... 3-1
Test and Setup Using Back-to-Back Cables with Internal Bit Synchronizer Disabled..... 3-1
Test and Setup Using Back-to-Back Cable with Internal Bit Synchronizer Option Enabled..... 3-2

DEC1000A136 Pinout Information 3-3

DEC1000A136 Decoder Installation..... 3-4

Interconnecting Cable Installation 3-6

Maintenance..... 3-6
Cleaning..... 3-6

APPENDIX A A-1

OPTION Commands A-1
OPTION1 NN A-3
OPTION2 NN A-4
OPTION3 NN A-6
OPTION4 NN A-6
OPTION Command Examples A-6

APPENDIX B B-1

Hexadecimal to Decimal Conversion B-1

Chapter 1 Introduction

About This Manual

This manual is a user guide for the DEC1000A136, a member of Enerdyne's family of ADVS[®]-compatible video decoders. The DEC1000A136 is a compact, self-contained unit requiring 28 VDC power. See Figure 1-1.

This manual contains the information needed to install, operate, and maintain the DEC1000A136 Decoder. If you have any questions or problems that cannot be resolved using this manual, call Customer Support at 619-438-6000 for help.

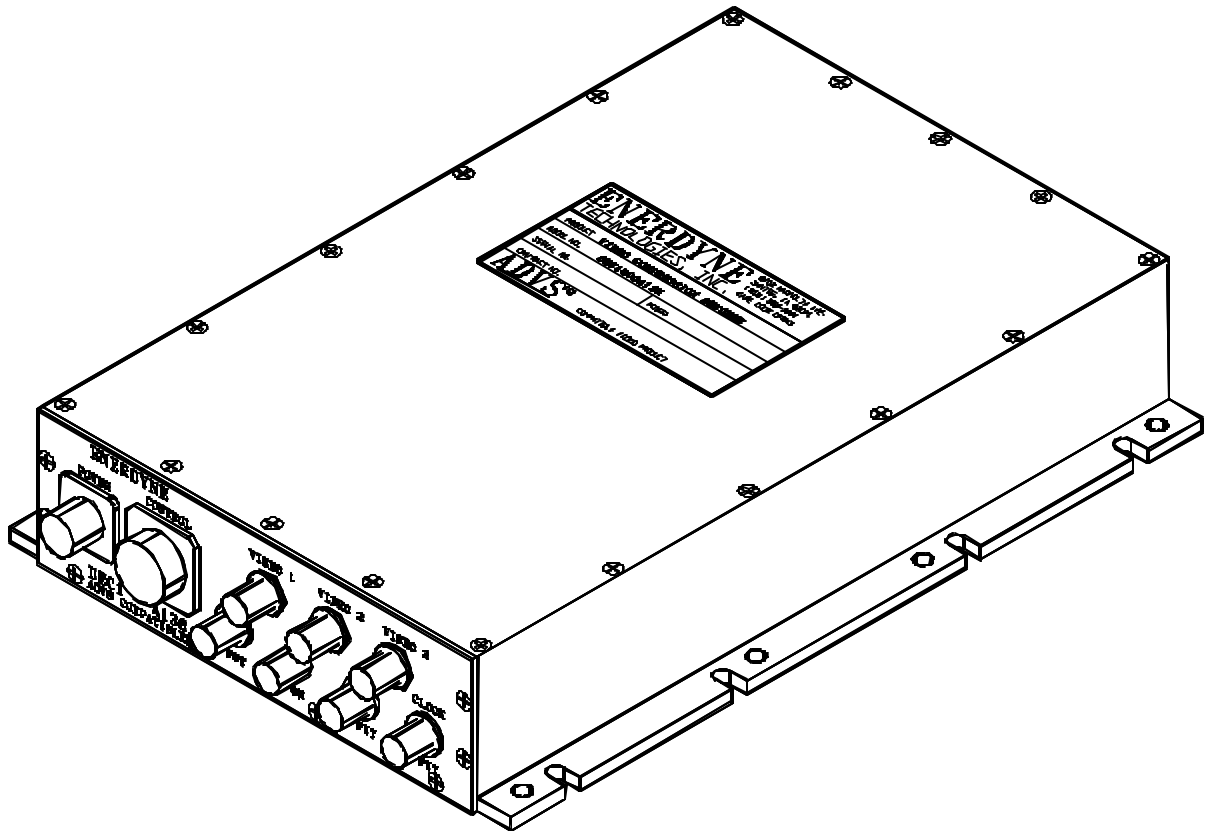

Figure 1-1 DEC1000A136 Decoder

Theory of Operation

DEC1000A136 Decoder Functional Description

The DEC1000A136 decoder decompresses digital video data and converts the digital video into an analog signal output in any of the formats listed in Table 1-1. The input data stream is the compressed video output from an ADVS[®]-compatible video encoder (such as the ENC1000A94). A demultiplexer (DMUX1000) strips away data (Synchronous Serial (SS), audio, Asynchronous Serial (AS)) that has been multiplexed into the data stream by the encoder and outputs these data separately from the video. The decoder and the multiplexer are controlled via the EIA-232 control port using a dumb terminal or a PC with a terminal emulation program.

Table 1-1 Analog Video Input Formats

Color	Monochrome
NTSC Composite	EIA-170
PAL Composite	CCIR
Y/C	

Compressed video and clock signals may be connected to the decoder inputs as shown in Figure 1-2. When the DMUX option is not enabled, the compressed video input and clock input signal is TTL. When the DMUX is enabled, the compressed video input and clock input can be software selected as either TTL or EIA-422. If the incoming data stream includes data packets other than video (SS, audio, or AS) that have been multiplexed in with the video, then the decoder must be configured with the DMUX1000 demultiplexer enabled. The DMUX1000 separates the non-video packets from the video and outputs the different data types on separate channels. The serial video data is then converted to parallel data and decompressed. Finally, the digital video is converted to an analog signal for display or recording.

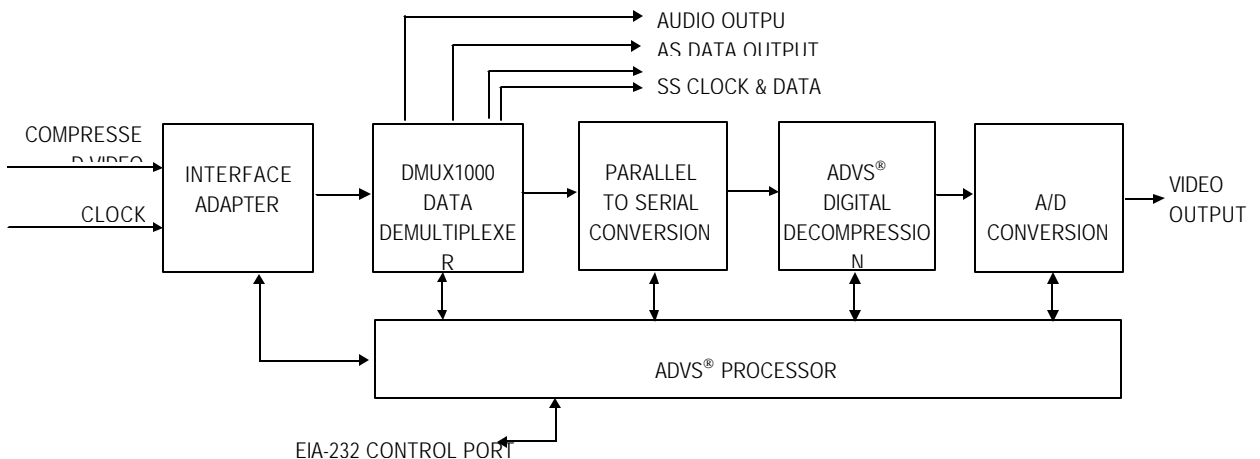

Figure 1-2 DEC1000A136 Decoder Functional Block Diagram

DMUX1000 Data Demultiplexer

The DMUX1000 Data Demultiplexer de-multiplexes the data that was combined with the compressed video stream by the ADVS[®] encoder (Figure 1-3) and outputs the data on separate user accessible ports. The system can combine compressed video, audio, Asynchronous Serial (AS) and Synchronous Serial (SS) digital data into one transmission over any digital transmission facility. The audio data channel output is a 1 Vpp, 600 Ohm audio signal with a frequency response of 300 Hz to 3000 Hz. The simplex asynchronous data channel is an EIA-232 interface and is user programmable from 300 baud to 9600 baud in five steps. The SS synchronous data channel outputs SS data and clock. SS output level is EIA-422 or TTL. The user supplied SS clock rate may be as high as 49% of the total transmission link frequency. Additionally, a Forward Error Correction (FEC) feature is available for systems using wireless transmission. FEC is discussed in more detail in the following paragraphs.

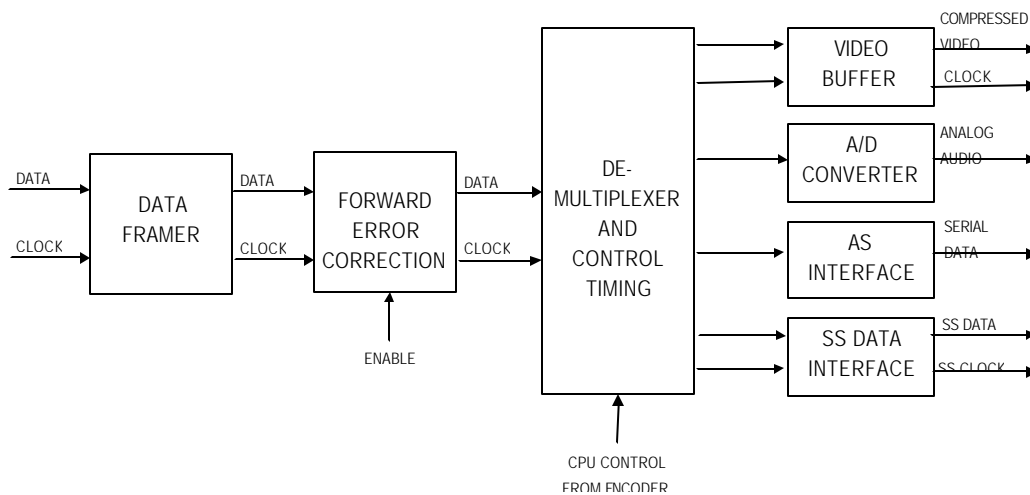

Figure 1-3 DMUX1000 Data Demultiplexer Functional Block Diagram

FEC allows the user to transmit data in a noisy environment by correcting a number of bit errors received at the ground site. The scheme used by Enerdyne is a Reed-Solomon based algorithm. The encoder applies a Reed-Solomon algorithm that generates check bytes for a transmission message. The check bytes and message data form an error correcting code word that can be transmitted over noisy transmission media. The decoder at the receiving end of the line uses the check bytes to detect and correct any errors that are introduced by line noise into the transmitted code word. If used, FEC must be selected at both the encoder and decoder.

Typical Application

Figures 1-4 and 1-5 are examples of a typical user installation for the DEC1000A136. Various configurations are possible and are dependent on user requirements and equipment. If you require assistance configuring your system, call Customer Support at 619-438-6000.

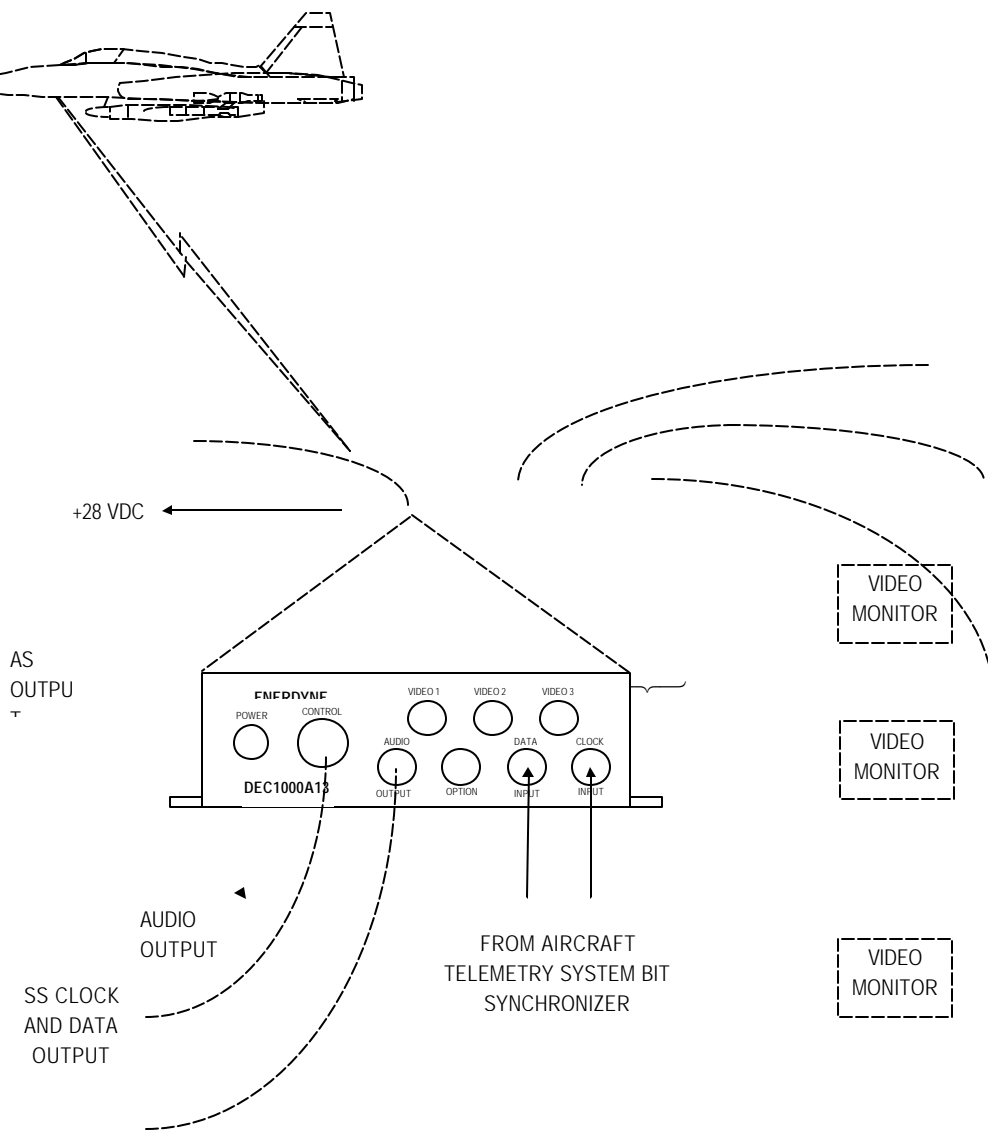

Figure 1-4. Typical Application for DEC1000A136 with TTL Inputs

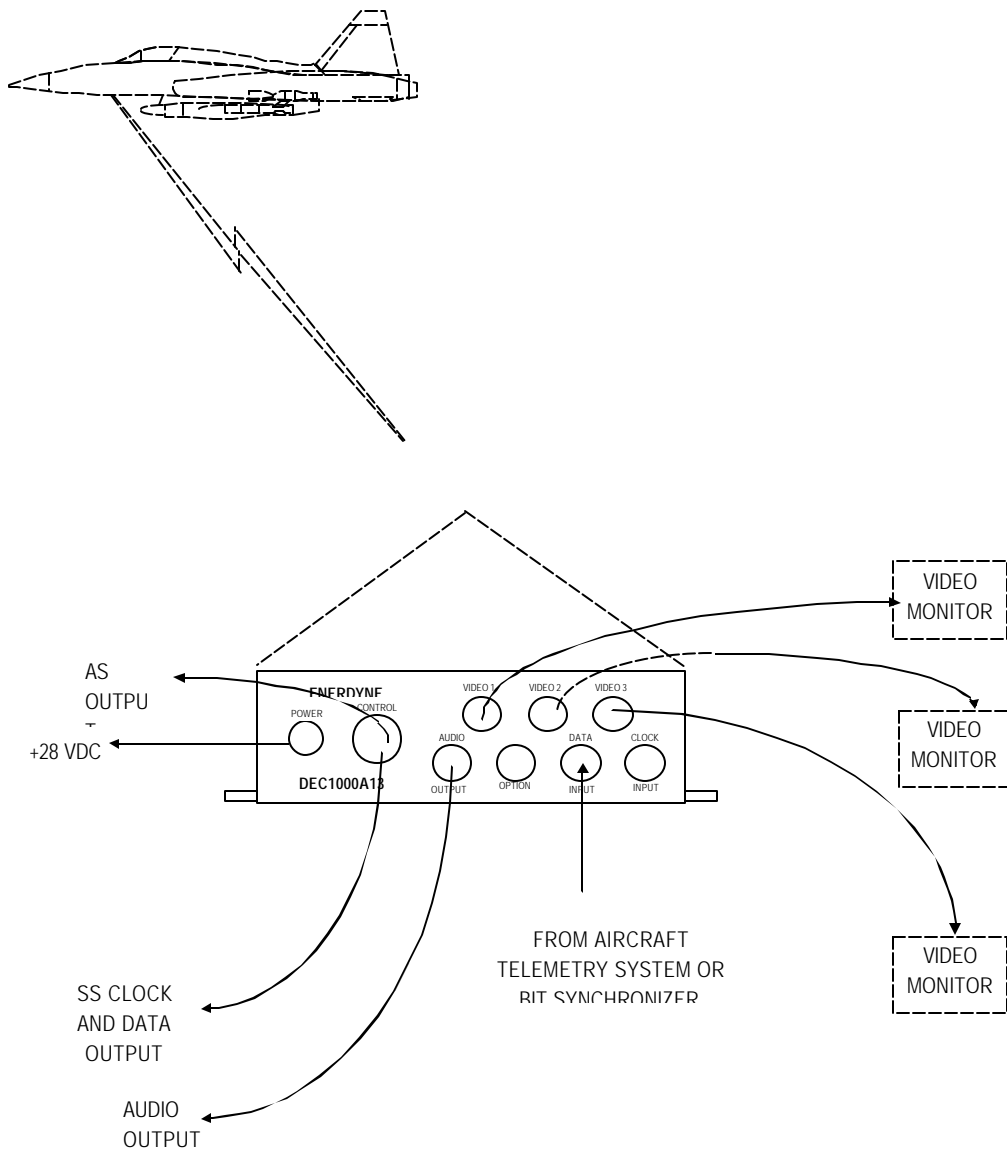

Figure 1-5 Typical Application for DEC1000A136 with Internal Multi-Frequency DBS12 Bit Synchronizer Option

DEC1000A136 Specifications

ELECTRICAL	
Video Outputs	NTSC Composite or Y/C, 1 Vpp, 75 Ohm, 60 Hz PAL Composite or Y/C, 1 Vpp, 75 Ohm, 50 Hz CCIR Monochrome, 1 Vpp, 75 Ohm, 50 Hz EIA170 Monochrome, 1 Vpp, 75 Ohm, 60 Hz
Video Output Connectors	BNC-type isolated ground (3)
Horizontal Resolution	560, 280 or 140 pixels/line, user selectable
Vertical Resolution	240 lines/field digitized, 480 lines/frame 60 Hz 288 lines/field digitized, 576 lines/frame 50 Hz
Data & Clock Input Rates	Internal source: 19 Kbps to 20 Mbps* External Source - any rate up to 20 Mbps*
Data & Clock Input Connections	BNC-type isolated ground or optional EIA-422
Optional Bit Synchronizer	BNC-type isolated ground (marked "DATA")
Power	28 VDC (+12 VDC optional)
MECHANICAL	
Dimensions	7.5 in. wide x 10.5 in. long x 2.0 in. high
Weight	5 lbs.
Enclosure Materials	6061 aluminum, stainless steel hardware.
ENVIRONMENTAL	
Operational Temperature	0°C to +50°C normal range (opt. -20°C to +70°C)
Non-Operating Temperature	-55°C to +85°C
Humidity	95% maximum (non-condensing)
Vibrations	
Operational	Not applicable
Transportation	As per MIL-STD-810E, method 514.4, procedure 1, figures 514.4-1/2/3 in transit, when packaged in shipping box
Shock, Operational	As per MIL-STD-810E, method 516.4, procedure 1, figures 516.4-4 (20 g, 11 ms sawtooth)

* 10 Mbps maximum with DMUX enabled.

Chapter 2 Decoder Operation

Series 1000 Decoding Equipment

This chapter provides detailed explanations of each operating mode and option available for the DEC1000A136 ADVS[®]-compatible Color Video Compression Decoder.

Software Interface

The decoder contains all communication software required to communicate with terminal hardware. All the user needs to provide is a 'dumb' terminal operating at 9600 baud or a PC running terminal emulation software set for half duplex (local echo) mode.

Upon power-up, the decoder-to-terminal link will print the logon message followed by power-on test messages. This will be followed by the system prompt. A typical power-on (or reset) sequence on a decoder will display the following*:

```
ADVS® Decoder Firmware Rev 6.3 092698-1411/Xencnov16+*
```

```
LCA configured from EPROM.  
DCT is setup.  
Formatter is setup.  
We are configured as an Decoder.
```

```
The firmware checksum XXXX verified as correct.
```

* This is a typical power-on message sequence. The actual message varies depending upon your software revision and installed options.

Checksum verified This message indicates that the EPROM and EEPROM checksums are correct. If an error message occurs here, execute the DEFAULT command to reset all parameters. If it still fails, contact the factory.

Following the power-up messages, the operating prompt is displayed as follows:

```
ADVS : \DECODER>
```

The prompt can be changed through the use of the prompt command. Refer to Chapter 2 for details.

There is *no* battery in the system. All software configuration values are stored in an EEPROM, and are retained through power-off/power-on cycles.

Using the Software Interface

Software interface commands consist of either a single word followed by carriage return (<CR>) or a single word followed by an argument string followed by a carriage return. Upper *or* lower case is accepted. A carriage return (<CR>) is required at the end of each line. Commands can be entered only on lines that display the system prompt. Typing ahead is not allowed. If no system prompt appears, press ENTER to display the prompt. If the prompt still fails to appear, check all connections and ensure that the terminal is set to 9600 baud.

The following commands are in alphabetical order. Some commands have alternate names and abbreviations (in parenthesis) for your convenience. A Hexadecimal to Decimal Conversion Table is included in Appendix B. Where applicable, the default settings are identified by the word 'default' next to the appropriate character string.

AUTO on/off

This command enables (on) or disables (off) the automatic parameter loading from the encoder operation. When AUTO is on (normal operation) the decoder operational parameters are updated automatically by input from the encoder bit stream when the equivalent parameter has changed on the encoder.

BAUD nn

This command selects the baud rate for the serial communications port. The baud rate will change after the next reset cycle. Baud rates supported are as follows:

nn	rate
00	300 baud
01	300 baud
02	300 baud
03	19200 baud
04	1200 baud
05	2400 baud
06	4800 baud
07	9600 baud (default)

CAUTION

Communication with the serial port is lost if an invalid baud rate is selected.

It is recommended that the baud rate be set to the highest rate supported by the terminal.

BSF mn

This command has no effect when the bit synchronizer option is not installed or enabled.

When the bit synchronizer option is installed and enabled, this command sets the bit synchronizer input frequency. Valid frequencies are from 20 Mbps to 19 Kbps. Values of 00 to 7F select a fixed frequency. 'HELP 04' displays the list of valid entries. An external clock can be selected by entering a value of 0F. The available frequencies are as follows:

	0x	1x	2x	3x	4x	5x	6x	7x
x0	02.500	01.250	00.625	00.312	00.156	00.078	00.039	00.019
x1	02.666	01.333	00.666	00.333	00.166	00.083	00.041	00.020
x2	02.857	01.428	00.714	00.357	00.178	00.089	00.044	00.022
x3	03.076	01.538	00.769	00.384	00.192	00.096	00.048	00.024
x4	03.333	01.666	00.833	00.416	00.208	00.104	00.052	00.026
x5	03.636	01.818	00.909	00.454	00.227	00.113	00.056	00.028
x6	04.000	02.000	01.000	00.500	00.250	00.125	00.062	00.031
x7	04.444	02.222	01.111	00.555	00.277	00.138	00.069	00.034
x8	05.000	02.500	01.250	00.625	00.312	00.156	00.078	00.039
x9	05.714	02.857	01.428	00.714	00.357	00.178	00.089	00.044
xA	06.666	03.333	01.666	00.833	00.416	00.208	00.104	00.052
xB	08.000	04.000	02.000	01.000	00.500	00.250	00.125	00.062
xC	10.000	05.000	02.500	01.250	00.625	00.312	00.156	00.078
xD	13.333	06.666	03.333	01.666	00.833	00.416	00.208	00.104
xE	20.000	10.000	05.000	02.500	01.250	00.625	00.312	00.156
xF	-EXT-	UCM	10.000	05.000	02.500	01.250	00.625	00.312

DATE mm/dd/yy

This command sets the default date used by the system. The date is entered in the month/day/year format and does not increment. When power is lost or a reset happens the system date is set to the last date entered.

DATEON yx

This allows the user to overlay the current date onto the output video. The position is set by the 'y' argument in the vertical direction and the 'x' argument in the horizontal direction. A value of y=0 is the top of the screen and a value of y=C is the bottom of the screen. A value of x=0 is the left of the screen and a value of x=C is the right of the screen. Any HEX value between 0 and C is valid, however, one of the two parameters must be zero (0) to keep the date display on the edge of the screen, and (0,0) is not displayed (use 0,1 or 1,0 to display the date in the top left corner). A DATEON command must be preceded by a VCLR command to clear the display buffer.

DEFAULT mn (GET mn)

This command resets all of the internal EEPROM variables to one of the two factory default settings. After this command is executed, a reset (Z or RESET command) should be performed. Default values may be set to the following:

mn	default variables
00	Standard NTSC decoder with 560 pixels, 5 Mbps bit rate, quantization set

to 18, tint, saturation, contrast, and brightness are set to default values.

- 01 Standard PAL decoder with 560 pixels, 5 Mbps bit rate, quantization set to 18 , tint, saturation, contrast, and brightness are set to default values.

To execute this command, the write-protect mode must be disabled. Write-protect is disabled by entering the PROTECT OFF command. NOTE: WHEN WRITE-PROTECT IS DISABLED, CONFIGURATION DATA CAN BE CHANGED OR INVALID DATA CONDITIONS MAY BE ENTERED.

The PROTECT ON command is automatically executed after the reset command is entered. Consultation with the factory is recommended before any other changes are made with write-protect disabled.

ERROR nn

This command enables or disables the error handling hardware. This parameter *must* be the same for both encoder and decoder. A value of 00 disables the mode; a value of 01 enables the mode. If enabled, the unit will exhibit a much greater tolerance when decoding unrecoverable errors, but requires about 10% more bandwidth from the system as compared to the disabled mode. This command must be followed by a reset.

nn	Status
00	OFF
01	ON

ES nn

This command displays decoder status.

HELP or ?

This command invokes the main HELP screen. Secondary HELP screens can be invoked via the HELP nn commands. *If video sync is lost and regained while viewing the HELP screen, video at the monitor will not be restored until you exit the HELP screen.*

HELP nn

These are the secondary HELP screens. The valid range for nn is 00 to 04 HEX.

nn	screen
00	Baud Rates
01	Factory Assistance
02	Demux Card Byte Definitions
03	Binary to Hex Conversion Table
04	Bit sync frequencies
05	AS Data channel baud rates

ID m

This command enables the decoder to process received compressed video data packets with the selected video channel(s) identification code. The normal default value is 00. Ensure that both the encoder and the decoder are programmed to the same identification code (00 to 03) when processing a single video channel.

m	ID code
00	Channel 1 on current video
01	Channel 2 on current video
02	Channel 3 on current video
03	Channel 4 on current video

MINIBAR yx

This allows the user to overlay a miniature color-bar pattern onto the decoder screen. A value of 00 or FF disables this mode. A value of y=0 is the top of the screen, with a value of y=C the bottom of the screen. A value of x=0 is the left of the screen, a value of x=C the right of the screen.

PROMPT n . . . n

This command changes the system prompt. Up to eight characters can be accepted. Prompts entered using the PROMPT command will be retained through reset.

RELOAD

This command forces the decoder to reload all parameters from the encoder.

RESET (Z)

This command reinitializes all parameters from EEPROM and resets all internal timing.

S (STATUS)

This command displays all of the current operating modes that are stored in EEPROM. It also displays other current status and errors, if any.

SAVESCREEN

This command copies the entire overlay text screen into EEPROM. This will make a permanent copy of all graphics and messages that are reloaded every power cycle. This command also copies the time, date, and minibar if they are enabled before the savescreen is entered.

TCOLOR rrggbb

This command is used to select the color of the overlay text. The format is in RGB mode. Each of the rrggbb bytes selects how much of each color is to be used. 00 HEX is the minimum and FF HEX is the maximum. Example colors are listed below:

rrggbb color	
C00000	Red (primary colors are at 75% intensity)
00C000	Green

0000C0	Blue
C0C0C0	White
C0C000	Yellow
C000C0	Violet
00C0C0	Cyan

TEST nn

This command puts the system into VIDEO test mode. The system will display solid colors in accordance with the following table:

100% amplitude		75% amplitude		50% amplitude		25% amplitude	
nn	color	nn	color	nn	color	nn	color
00	black	08	black	10	black	18	black
01	red	09	red	11	red	19	red
02	green	0A	green	12	green	1A	green
03	blue	0B	blue	13	blue	1B	blue
04	yellow	0C	yellow	14	yellow	1C	yellow
05	cyan	0D	cyan	15	cyan	1D	cyan
06	violet	0E	violet	16	violet	1E	violet
07	white	0F	white	17	white	1F	white

The decoder also provides the following test patterns:

nn	Test
20	colorbar
21	SMPTE colorbar
22	grey bars

To return to normal operation after you are done with this test, a RESET or Z command must be entered.

TIME hh:mm:ss

This command sets the current system time. The time is entered in the 24 hour military format. When a reset or power failure occurs, system time is reset to 00:00:00. System time is also reset to 00:00:00 when system setup parameters such as Quantization and Resolution are changed.

TIMER nn

This command displays the system time at the location designated. The position is set by the 'y' argument in the vertical direction and the 'x' argument in the horizontal direction. A value of y=0 is the top of the screen and a value of y=C is the bottom of the screen. A value of x=0 is the left of the screen and a value of x=C is the right of the screen. Any HEX value between 0 and C is valid, however, one of the two parameters must be zero (0) to keep the timer display on the edge of the screen, and (0,0) is not displayed (use 0,1 or 1,0 to display the timer in the top left corner). A TIMER command must be preceded by a VCLR command to clear the display buffer.

NOTE: when operating in PAL format, the range is 0 to E in HEX.

TTEST

This command displays the overlay graphics plane character set on the screen. The screen is erased by entering the VCLR command.

V mn

This is the command used to display text as an overlay on the video screen. V 0n is used for left justified text and V 1n is used for centered text. For example, entering 'V 14 Mission #1' will display the words 'Mission #1' auto-centered on text line number 4. Entering V 14 with no text will erase that line. The text is displayed in the current color selected by the TCOLOR command. All of the text on the screen can be erased with the VCLR command. Upper and lower case is allowed. The character set can be viewed with the TTEST command. Overlay messages are lost during a power or reset sequence. The valid range of text line numbers is from 0 HEX to F HEX.

VCLR

This command erases all text from the text overlay plane. No other parameters are used.

YC on/off

This command toggles output BNCs J2 and J3 to YC outputs respectively.

Option Commands

The DMUX1000 Data Demultiplexer is configured by enabling selected bits in four eight-bit option registers. This is done using the commands OPTION1, OPTION2, OPTION3, and OPTION4, described in Appendix A. However, in order to have a clear understanding of how to select the proper configuration, it is necessary to review the following rules and information.

Demultiplexer Overview

The multiplexer frames the encoder serial data output in a series of eight recurring time slots as shown in Figure 2-1. Each time slot may be configured to contain compressed video data and Synchronous Serial (SS), Asynchronous Serial (AS) or audio data when FEC is not enabled. If FEC is enabled, time slot 8 is reserved for FEC. When the multiplexer is disabled, (**OPTION1 08**) all available transmission bandwidth is allocated to video. When the multiplexer is enabled, framing overhead consumes $\approx 7.7\%$ of the transmission link bandwidth. The maximum SS rate is 50% of the transmission link bandwidth when audio, AS, and FEC are not enabled. When any combination of audio, AS or FEC is enabled, the maximum SS rate is 25% of the transmission link bandwidth. Refer to Table 2-1 for multiplexer bandwidth usage. Each group of eight time slots is 130 bits long regardless of link rate. Each time slot is 16 bits long with 2 framing bits at the start of time slot 1 ($130 \text{ bits} = (8 \times 16) + 2$). The allocation of time slots on the decoder must be identical to the allocation of time slots on the encoder. This allows the demultiplexer to synchronize time slots, and to identify the type of data contained in each time slot

when a time slot is allocated for data. Rules for designating time slots are described in the following paragraphs. These rules are identical for the encoder and the decoder.

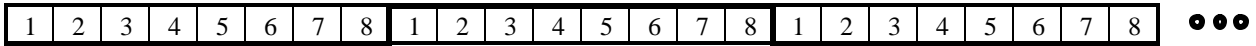

Figure 2-1 Encoder Serial Data Output Time Slot Sequencing

Audio Data Rules

Audio data will consume 64 Kbps of link bandwidth. Each time slot designated for audio will contain 8 bits of audio data if an audio packet is ready, otherwise compressed video will be inserted. If only audio data is being multiplexed with compressed video, all time slots should be designated audio slots. This will result in the highest audio quality at the decoder output. If audio and SS or AS data are being multiplexed with compressed video, slots should be assigned on an interleaved basis (Figure 2-2) to ensure maximum audio quality.

1	2	3	4	5	6	7	8
AUDIO	SS	AS	AUDIO	SS	AS	AUDIO	SS
SS	AUDIO	AS	SS	AUDIO	AS	SS	FEC
AUDIO	SS	AUDIO	SS	AUDIO	SS	AUDIO	SS
SS	AUDIO	SS	AUDIO	SS	AS	SS	FEC

Figure 2-2 Time Slot Interleaving Examples

Table 2-1 Multiplexer Bandwidth Usage

Configuration	Transmission Link Bandwidth Usage					
	SS	AUDIO	AS	FEC	VIDEO	MULTIPLEXER OVERHEAD
Video & SS	≤50%	-	-	-	Remainder	7.7%
Video, SS, Audio	≤25%	64Kbit	-	-	Remainder	7.7%
Video, SS, Audio, AS	≤25%	64Kbit	Baud Rate	-	Remainder	7.7%
Video+SS+Audio+AS+FEC	≤25%	64Kbit	Baud Rate	11.5%	Remainder	7.7%
MUX Disabled (OPTION1 08)	-	-	-	-	100%	-

SS Data Rules

Each time slot designated for SS may contain up to 50% SS data and the remaining bits will be compressed video. When FEC is not enabled, the SS clock rate may be as high as 50% of the link rate, assuming the FEC, AUDIO, and AS data channels are not enabled.

AS Data Rules

As with SS and Audio data time slots, time slots designated for AS should be interleaved as shown in Figure 2-2. The baud rate (OPTION2 (bits 4-6) command) at the decoder must be set to one baud rate higher than at the encoder. The baud rate at the encoder and the decoder can be the same if there is at least one character delay between AS characters. AS data is fixed at eight bits with one start bit, one stop bit, and no parity. Each time slot designated as AS will contain one eight-bit character. The remaining bits will be compressed video

Chapter 3 Installation and Maintenance Procedures

Introduction

This chapter should be used as an aid in installing and configuring the DEC1000A136. This chapter also covers configuration information for the DEC1000A136 DMUX data demultiplexer.

Test and Setup Using Back-to-Back Cables with Internal Bit Synchronizer Disabled

Initial system software setup is performed on the bench using the test setup configuration shown below (Figure 3-1). Refer to the equipment pinouts included in this chapter.

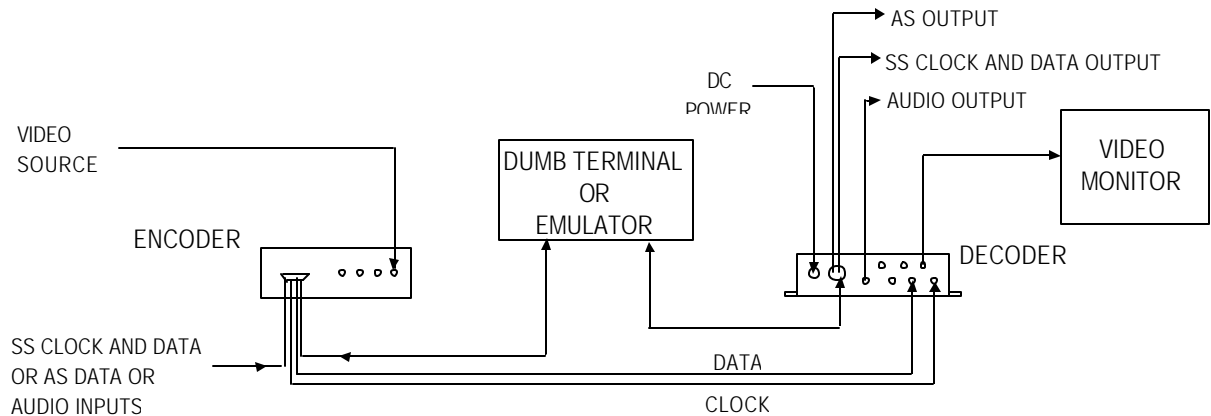

Figure 3-1. DEC1000A136 Test and Setup Configuration with Internal Bit Synchronizer Disabled

All commands are entered on a dumb terminal or PC with terminal emulator software as described in Chapter 2. It is recommended that initial setup commands be invoked in the order in which they are presented in this section. Refer to Chapter 2 for decoder operation and commands.

Step 1 - Initial power up.

Configure the test system as shown in Figure 3-1. The decoder must be supplied with 28 or optional 12VDC power. Power up the unit, and ensure that the logon messages conform to the description in Chapter 2.

NOTE

Perform Step 2 only if DMUX1000
Data Demultiplexer is required.

Step 2 - Set EMUX option data and FEC commands.

Use the OPTION commands to configure data (audio, AS, or SS) and FEC options as described in Chapter 2 and Appendix A.

NOTE

It is recommended that the decoder be configured for data transmission using the OPTION commands before the data multiplexer is enabled via encoder OPTION1 command.

Test and Setup Using Back-to-Back Cable with Internal Bit Synchronizer Option Enabled

All commands are entered on a dumb terminal or PC with terminal emulator software as described in Chapter 2. It is recommended that initial setup commands be invoked in the order in which they are presented in this section. Refer to Chapter 2 for decoder operation and commands.

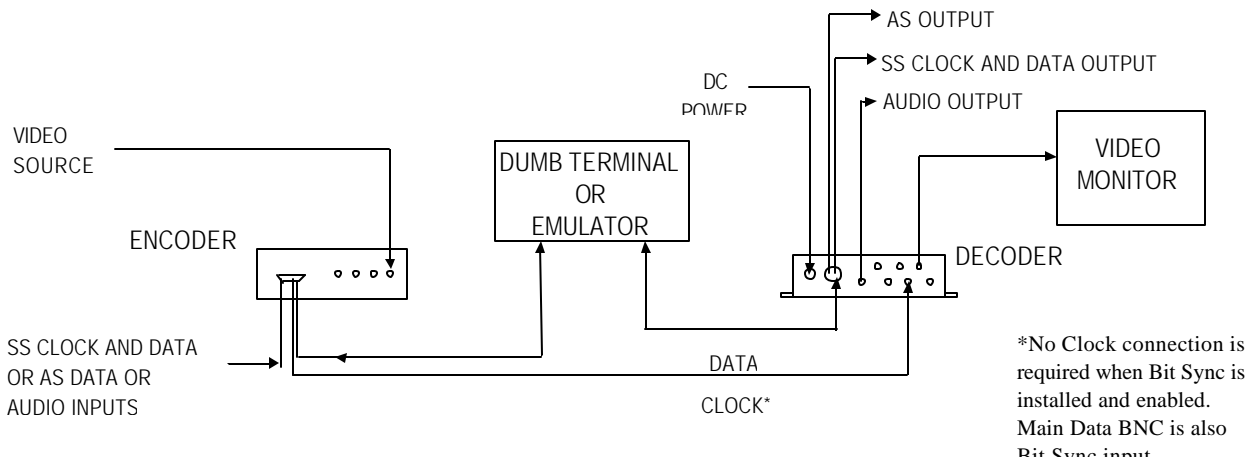

Figure 3-2 DEC1000A136 Decoder Setup and Test Configuration with Optional DBS12 Multi-Frequency Bit Synchronizer Enabled

Step 1 - Initial power up.

Configure the test system as shown in Figure 3-2. The decoder must be supplied with 28 VDC power. Power up the unit, and ensure that the logon messages conform to the description in Chapter 2.

NOTE

Perform Step 2 only if DMUX1000 Data Multiplexer is required.

Step 2 - Set EMUX option data and FEC commands.**Step 3 – Set Bit Synchronizer frequency using BSF Command. (See Chapter 2)**

Use the OPTION commands to enable the bit synchronizer and configure data (audio, AS, or SS) and FEC options as described in Chapter 2 and Appendix A.

DEC1000A136 Pinout Information

Video Output:	VIDEO 1, 2, 3 *	Connector: BNC
Audio Input:	AUDIO OUTPUT	Connector: BNC
Future option: not used	OPTION	Connector: BNC
**System Data input:	DATA INPUT	Connector: BNC
SystemClock input:	CLOCK INPUT	Connector: BNC

Power input: POWER		Connector: 3-pin circular
Pin Number	Signal	Description
A	Positive supply	Main power input (+28 VDC or +12 VDC, Factory Preset)
B	Supply return	Main power input return
C	Ground	

All other inputs/outputs: CONTROL		Connector: 22-pin circular (Figure 3-3)
Pin Number	Signal	Description
1	Clock input	System Clock input +
2	Ground	
3	Clock input	System Clock input -
4	Data input	System Data input +
5	Ground	
6	Data input	System Data input -
7	Clock output	SS clock output +
8	Ground	
9	Clock output	SS Clock output -
10	Data output	SS Data output +
11	Ground	
12	Data output	SS Data output -
13	TXD EIA-232	EIA-232 output, Decoder control
14	RXD EIA-232	EIA-232 input, Decoder control
15	Ground	

16	Data output	AS data output
18	Ground	
19	Spare	
20	Spare	
17, 21, 22	Not used	

*VIDEO 2 = Y, VIDEO 3 = C when Y/C output is enabled

**Also used for bit synchronizer input, when bit synchronizer is installed and enabled.

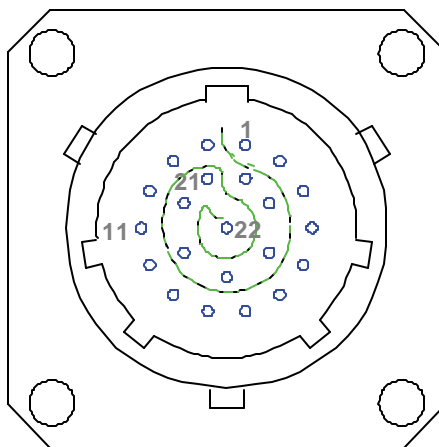
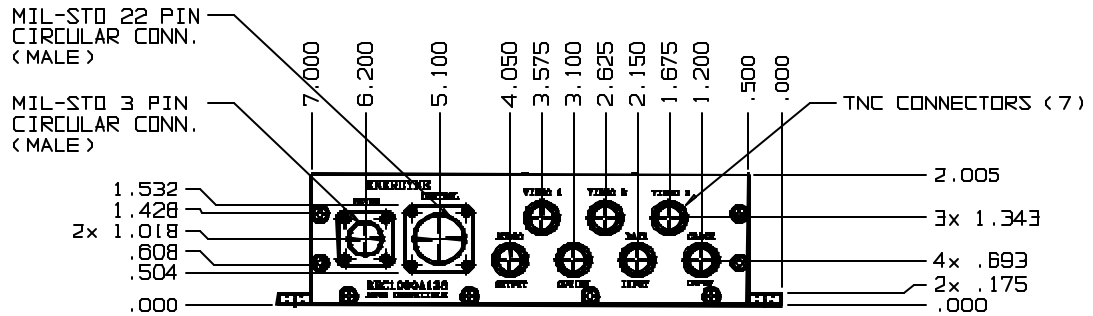
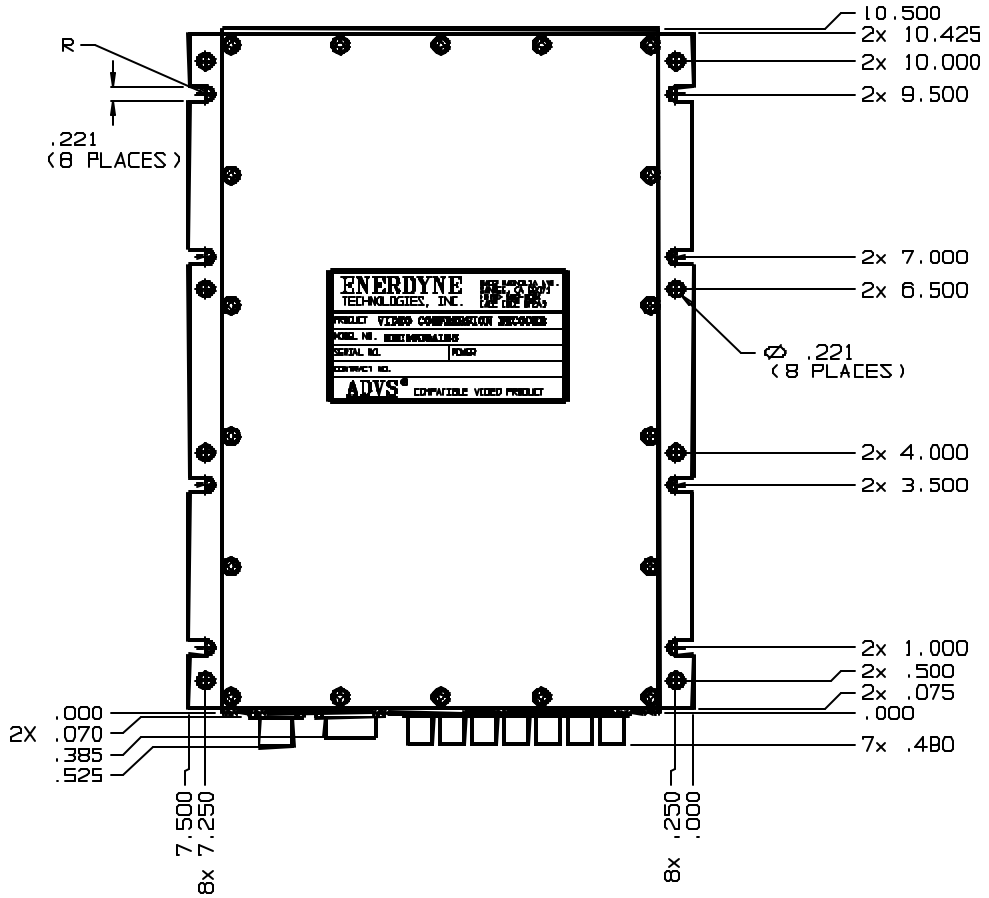

Figure 3-3 Circular Connector Pin Numbering

DEC1000A136 Decoder Installation

Installation footprint for the DEC1000A136 is shown below. Special shock mounting or vibration dampening is not required. Mounting bolts should be protected from vibrating loose. Proper grounding is required.



DEC1000A136 Decoder Mounting Dimensions

Interconnecting Cable Installation

Ensure that all BNC connectors are fully seated. Circular connectors must be firmly seated.

Dress and secure all cables in accordance with local safety and EMI standards. The Enerdyne DEC1000A136 ADVS[®]-compatible Color Video Compression Decoder requires very little maintenance. Helpful hints on maintaining the equipment are provided in the following paragraphs.

Maintenance

Cleaning

A mild non-abrasive cleanser may be used to clean the unit. Care should be taken to prevent liquid from entering the connectors.

NOTE

There are no user serviceable parts located within the unit. Opening the unit or removing a circuit card will void the warranty. Units requiring service during the warranty period must be returned to the factory.

APPENDIX A

OPTION Commands

The four OPTION commands provide control of the demultiplexer through the setting of control bits that define demultiplexer function. The bandwidth available for multiplexed data is divided into eight equal segments, or time slots. All eight time slots can be individually allocated to SS, audio or AS. When FEC is enabled, the eighth time slot of every frame is reserved for FEC, The remaining seven are still available for audio, SS or AS. A slot cannot be allocated to more than one data type. Slots may not be allocated through successive uses of an OPTION command; that is, the user cannot invoke OPTION3 to reserve slot #6 for AS data, and then use OPTION3 again to reserve bit #3. There are other specific conditions governing the transmission of each of the data types, which are covered in Chapter 2, Option Commands.

The four OPTION commands all accept input arguments in the same format (see Figure A-1). Each of the two digits *nn* is a HEXADECIMAL number in the range 0-F. The right digit corresponds to the low order four bits, the left digit corresponds to the upper four bits.

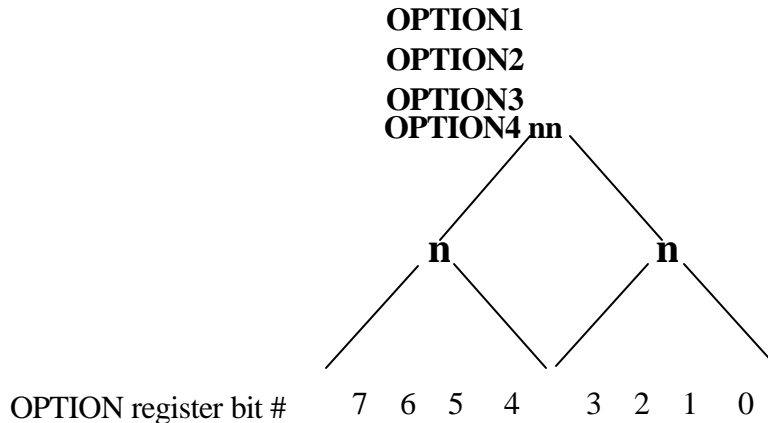

Figure A-1 OPTION Command Output Arguments

In other words, each argument *n* is a HEXADECIMAL representation of a 4 bit binary number. Table A-1 provides an easy way to select the appropriate digit. For example, if the proper configuration required that the high order bits be set to 1011, and the low order bits to 1110, a quick look at the table shows that the left digit should be HEXADECIMAL “B” and the right digit should be HEXADECIMAL “E”. The correct argument string is BE.

Table A-1 Option Register Hexadecimal Conversion Chart

LOW REGISTER BITS	3	2	1	0
HIGH REGISTER BITS	7	6	5	4
BIT VALUE	(8)	(4)	(2)	(1)
0	0	0	0	0
1	0	0	0	1
2	0	0	1	0
3	0	0	1	1
4	0	1	0	0
5	0	1	0	1
6	0	1	1	0
7	0	1	1	1
8	1	0	0	0
9	1	0	0	1
A	1	0	1	0
B	1	0	1	1
C	1	1	0	0
D	1	1	0	1
E	1	1	1	0
F	1	1	1	1

The following describes the function of each OPTION command. The DEC1000A136 decoder can function with any ADVS[®]-compatible encoder. It is important that the encoder and the decoder configurations match, or unpredictable transmission results will occur. Generally speaking, it is more convenient to set options on the decoder first, then proceed to the encoder. Refer to the encoder manual for encoder OPTION command settings.

CAUTION

It is important to ensure that a slot is not assigned to more than one function. For example, OPTION4 should not be used to assign slot #6 to audio after OPTION3 has been used to assign the same slot to AS. Unpredictable results may occur.

NOTE

Time slots are designated to SS unless OPTION3 and OPTION4 commands are used to designate slots as audio, AS or FEC.

OPTION1 NN

This command allows the user to enable or disable the various demultiplexer functions controlled by each bit. The software revision and check word are available on the control terminal screen at power-up. Decoder OPTION1 bit settings are as follows:

DECODER FUNCTION WHEN BIT = 1				
Bit Number	Default	Serial Number 0430 or LOWER	Serial Number 0431 through 0767	Serial Number 0683
0	0	FEC Enable	FEC Enable	FEC Enable
1	0	Baud Rate Select 'X'	Baud Rate Select 'X'	Baud Rate Select 'X'
2	0	Baud Rate Select 'Y'	Baud Rate Select 'Y'	Baud Rate Select 'Y'
3	0	Baud Rate Select 'Z'	Baud Rate Select 'Z'	Baud Rate Select 'Z'
4	0	Must be = 0	Must be = 0	Must be = 0
5	0	Main Clock Input Invert	Main Clock Input Invert	Main Clock Input Invert
6	0	Must be = 0	Must be = 0	Enable Bit Sync
7	0	Must be = 0	Must be = 0	Must be = 0

DECODER FUNCTION WHEN BIT = 1				
Bit Number	Default	Serial Number 0843, 0844, and 0870	Serial Number 0850 through 0853	Serial Number 0994 through 0998, 1001 through 1003, and 1013
0	0	FEC Enable	FEC Enable	FEC Enable
1	0	Baud Rate Select 'X'	Baud Rate Select 'X'	Baud Rate Select 'X'
2	0	Baud Rate Select 'Y'	Baud Rate Select 'Y'	Baud Rate Select 'Y'
3	0	Baud Rate Select 'Z'	Baud Rate Select 'Z'	Baud Rate Select 'Z'
4	0	Enable Randomizer	Enable Randomizer	Enable Randomizer
5	0	Main Clock Input Invert	Main Clock Input Invert	Main Clock Input Invert
6	0	Must be = 0	Must be = 0	Must be = 0
7	0	Disable Auto Frame Detection	Disable Auto Frame Detection	Disable Auto Frame Detection

DECODER FUNCTION WHEN BIT = 1				
Bit Number	Default	Serial Number 1012, and 1028 through 1031	Serial Number 1055 and HIGHER	not used
0	0	FEC Enable	FEC Enable	
1	0	Baud Rate Select 'X'	Baud Rate Select 'X'	
2	0	Baud Rate Select 'Y'	Baud Rate Select 'Y'	
3	0	Baud Rate Select 'Z'	Baud Rate Select 'Z'	
4	0	Enable Randomizer	Enable Randomizer	
5	0	Main Clock Input Invert	Main Clock Input Invert	
6	0	Must be = 0	Bit Sync Phase 1=(-), 0=(+)	
7	0	Disable Auto Frame Detection	Enable Bit Sync	

Note that bits 1, 2 and 3 determine baud rate on the decoder AS data output in accordance with the following table:

Baud Rate	BIT X	BIT Y	BIT Z
38400	0	0	0
19200	1	0	0
9600	0	1	0
4800	1	1	0
2400	0	0	1
1200	1	0	1
600	0	1	1
300	1	1	1

RANDOMIZER BIT 4-The Randomizer limits the number of consecutive 1's or 0's in the encoder output data stream to 15. The Randomizer should be used when digital transmission equipment or bit synchronizers between the encoder and DEC1000A136 or DEC1000R10 decoder require randomized data to prevent long strings of 1's or 0's. When the encoder Randomizer bit (OPTION1 command) is set to 1 the decoder Randomizer bit (OPTION1 command) must be set to 1 to derandomize the data for decoding and proper display.

Errors introduced after the data is randomized are multiplied during the derandomization process. The decoder derandomizer has an error multiplication factor of 3 for isolated bit errors (separated from adjacent bit errors by at least 15 bits). An isolated bit error will produce 3 errors in the output data; the original bit error and 2 additional errors 14 and 15 bits later. In addition, a burst of errors occurring after the data has been randomized will produce a burst of errors in the derandomized output. The number of errors in the output depends on the distribution of errors in the burst and can be greater than, equal to or less than the number of errors in the input to the derandomizer. However, the derandomizer always increases the number of bits between the first and last error in the burst by 15.

OPTION2 NN

This command allows the user to enable or disable the various demultiplexer functions controlled by each bit. Decoder OPTION2 bit settings are as follows:

Bit Number	Default	DECODER FUNCTION WHEN BIT = 1		
		Serial Number 0430 or LOWER	Serial Number 0431 through 0767	Serial Number 0683
0	0	SS Clock Output Invert	SS Clock Output Invert	SS Clock Output Invert
1	0	SS Data Output Invert	SS Data Output Invert	SS Data Output Invert
2	0	Main Data Input Invert	Main Data Input Invert	Main Data Input Invert
3	0	Use EIA-422 for Main Interface	Decoder Source Select 'A'	Decoder Source Select 'A'

ENERDYNE TECHNOLOGIES, INC.

877-363-7396

4	0	Must be = 0	Decoder Source Select 'B'	Decoder Source Select 'B'
5	0	Must be = 0	Multiplexer Source, 0=TTL, 1=422	Enable 3 MHz Bit Sync
6	0	Must be = 0	Must be = 0	Must be = 0
7	0	Must be = 0	Must be = 0	Must be = 0

DECODER FUNCTION WHEN BIT = 1				
Bit Number	Default	Serial Number 0843, 0844, and 0870	Serial Number 0850 through 0853	Serial Number 0994 through 0998, 1001 through 1003, and 1013
0	0	SS Clock Output Invert	SS Clock Output Invert	SS Clock Output Invert
1	0	SS Data Output Invert	SS Data Output Invert	SS Data Output Invert
2	0	Main Data Input Invert	Main Data Input Invert	Main Data Input Invert
3	0	Decoder Source Select 'A'	Decoder Source Select 'A'	Decoder Source Select 'A'
4	0	Decoder Source Select 'B'	Decoder Source Select 'B'	Decoder Source Select 'B'
5	0	Multiplexer Source, 0=TTL,1=422	Multiplexer Source, 0=TTL,1=422	Multiplexer Source, 0=TTL,1=422
6	0	Must be = 0	Must be = 0	Must be = 0
7	0	Must be = 0	Must be = 0	Must be = 0

DECODER FUNCTION WHEN BIT = 1				
Bit Number	Default	Serial Number 1012, and 1028 through 1031	Serial Number 1055 and HIGHER	not used
0	0	SS Clock Output Invert	SS Clock Output Invert	
1	0	SS Data Output Invert	SS Data Output Invert	
2	0	Main Data Input Invert	Main Data Input Invert	
3	0	Decoder Source Select 'A'	Decoder Source Select 'A'	
4	0	Decoder Source Select 'B'	Decoder Source Select 'B'	
5	0	Multiplexer Source, 0=TTL,1=422	Multiplexer Source, 0=TTL,1=422	
6	0	Must be = 0	Must be = 0	
7	0	Must be = 0	Must be = 0	

DECODER SOURCE SELECT					
Serial Number 0431 through 0767	Serial Number 0683	Serial Number 0843, 0844, and 0870	Serial Number 0850 through 0853	BIT A	BIT B
TTL	TTL	TTL	NOT USED	0	0
422	422	422	NOT USED	1	0
TTL	MUX CARD	TTL	NOT USED	0	1
422	NOT USED	422	TTL/422	1	1

DECODER SOURCE SELECT					
Serial Number 0994 through 0998, and 1001 through 1003	Serial Number 1012, and 1028 through 1031	Serial Number 1055 and HIGHER	not used	BIT A	BIT B
NOT USED	TTL/422	TTL/422		0	0

ENERDYNE TECHNOLOGIES, INC.

877-363-7396

NOT USED	NOT USED	NOT USED		1	0
NOT USED	NOT USED	NOT USED		0	1
TTL422	NOT USED	NOT USED		1	1

OPTION3 NN

This command allows the user to enable or disable time slots 1-8 for AS data. Encoder and decoder settings must be the same. Decoder OPTION3 bit settings are as follows:

Bit Number	Default	DECODER FUNCTION WHEN BIT = 1 All Serial Numbers
0	0	Enable Time Slot #1 for AS
1	0	Enable Time Slot #2 for AS
2	0	Enable Time Slot #3 for AS
3	0	Enable Time Slot #4 for AS
4	0	Enable Time Slot #5 for AS
5	0	Enable Time Slot #6 for AS
6	0	Enable Time Slot #7 for AS
7*	0	Enable Time Slot #8 for AS

* Set this bit to '1' if FEC is enabled by OPTION1.

This slot will be used for the FEC check word.

OPTION4 NN

This command allows the user to enable or disable time slots 1-8 for Audio data. Encoder and decoder settings must be the same. Decoder OPTION4 bit settings are as follows:

Bit Number	Default	DECODER FUNCTION WHEN BIT = 1 All Serial Numbers
0	0	Enable Time Slot #1 for Audio
1	0	Enable Time Slot #2 for Audio
2	0	Enable Time Slot #3 for Audio
3	0	Enable Time Slot #4 for Audio
4	0	Enable Time Slot #5 for Audio
5	0	Enable Time Slot #6 for Audio
6	0	Enable Time Slot #7 for Audio
7*	0	Enable Time Slot #8 for Audio

* Set this bit to '1' if FEC is enabled by OPTION1.

This slot will be used for the FEC check word

OPTION Command Examples

Table A-2 lists 16 sets of encoder and decoder option command settings and the resulting multiplexer configuration.

ENERDYNE TECHNOLOGIES, INC.

877-363-7396

Table A-2 Option Register Settings

SETTING	ENCODER REGISTERS				DECODER REGISTERS			
	OPTION1	OPTION 2	OPTION 3	OPTION 4	OPTION1	OPTION 2	OPTION 3	OPTION 4
1	08	XX	XX	XX	XX	XX	XX	XX
2	00	20	00	00	00	10	00	00
3	04	20	80	80	01	10	80	80
4	00	20	00	FF	00	10	00	FF
5	04	20	80	FF	01	10	80	FF
6	00	20	FF	00	04	10	FF	00
7	04	20	FF	80	05	10	FF	80
8	00	20	AA	00	04	10	AA	00
9	04	20	AA	80	05	10	AA	80
10	00	20	00	AA	00	10	00	AA
11	04	20	80	AA	01	10	80	AA
12	00	20	AA	55	04	10	AA	55
13	04	20	AA	05	05	10	AA	05
14	00	20	A4	09	04	10	A4	09
15	04	20	A4	89	05	10	A4	89
16	04	20	82	88	05	10	82	88
SETTING	MULTIPLEXER CONFIGURATION							
1	Disable multiplexer							
2	all slots SS, FEC disabled							
3	all slots SS, FEC enabled							
4	all slots Audio, FEC disabled							
5	all slots Audio, FEC enabled							
6	all slots AS, FEC disabled							
7	all slots AS, FEC enabled							
8	four slots SS, four slots AS, FEC disabled							
9	four slots SS, three slots AS, FEC enabled							
10	four slots SS, four slots audio, FEC disabled							
11	four slots SS, three slots audio, FEC enabled							
12	four slots AS, four slots audio, FEC disabled							
13	four slots AS, three slots audio, FEC enabled							
14	three slots SS, three slots AS, two slots audio, FEC disabled							
15	three slots SS, two slots AS, two slots audio, FEC enabled							
16	five slots SS, one slot AS, one slot audio, FEC enabled (factory setting)							

APPENDIX B

Hexadecimal to Decimal Conversion

Decimal	Hex	Decimal	Hex	Decimal	Hex	Decimal	Hex
0	00	32	20	64	40	96	60
1	01	33	21	65	41	97	61
2	02	34	22	66	42	98	62
3	03	35	23	67	43	99	63
4	04	36	24	68	44	100	64
5	05	37	25	69	45	101	65
6	06	38	26	70	46	102	66
7	07	39	27	71	47	103	67
8	08	40	28	72	48	104	68
9	09	41	29	73	49	105	69
10	A	42	2A	74	4A	106	6A
11	B	43	2B	75	4B	107	6B
12	C	44	2C	76	4C	108	6C
13	D	45	2D	77	4D	109	6D
14	E	46	2E	78	4E	110	6E
15	F	47	2F	79	4F	111	6F
16	10	48	30	80	50	112	70
17	11	49	31	81	51	113	71
18	12	50	32	82	52	114	72
19	13	51	33	83	53	115	73
20	14	52	34	84	54	116	74
21	15	53	35	85	55	117	75
22	16	54	36	86	56	118	76
23	17	55	37	87	57	119	77
24	18	56	38	88	58	120	78
25	19	57	39	89	59	121	79
26	1A	58	3A	90	5A	122	7A
27	1B	59	3B	91	5B	123	7B
28	1C	60	3C	92	5C	124	7C
29	1D	61	3D	93	5D	125	7D
30	1E	62	3E	94	5E	126	7E
31	1F	63	3F	95	5F	127	7F

Hexadecimal to Decimal Conversion (Continued)

Decimal	Hex	Decimal	Hex	Decimal	Hex	Decimal	Hex
128	80	160	A0	192	C0	224	E0
129	81	161	A1	193	C1	225	E1
130	82	162	A2	194	C2	226	E2
131	83	163	A3	195	C3	227	E3
132	84	164	A4	196	C4	228	E4
133	85	165	A5	197	C5	229	E5
134	86	166	A6	198	C6	230	E6
135	87	167	A7	199	C7	231	E7
136	88	168	A8	200	C8	232	E8
137	89	169	A9	201	C9	233	E9
138	8A	170	AA	202	CA	234	EA
139	8B	171	AB	203	CB	235	EB
140	8C	172	AC	204	CC	236	EC
141	8D	173	AD	205	CD	237	ED
142	8E	174	AE	206	CE	238	EE
143	8F	175	AF	207	CF	239	EF
144	90	176	B0	208	D0	240	F0
145	91	177	B1	209	D1	241	F1
146	92	178	B2	210	D2	242	F2
147	93	179	B3	211	D3	243	F3
148	94	180	B4	212	D4	244	F4
149	95	181	B5	213	D5	245	F5
150	96	182	B6	214	D6	246	F6
151	97	183	B7	215	D7	247	F7
152	98	184	B8	216	D8	248	F8
153	99	185	B9	217	D9	249	F9
154	9A	186	BA	218	DA	250	FA
155	9B	187	BB	219	DB	251	FB
156	9C	188	BC	220	DC	252	FC
157	9D	189	BD	221	DD	253	FD
158	9E	190	BE	222	DE	254	FE
159	9F	191	BF	223	DF	255	FF