

ENC1000A94

Color Video Compression Encoder

Features

- **ADVS® - Adaptive Digital Video Standard Compression Algorithm**
- **Real-Time Digital Compression of Full-Motion Video**
- **Small Size - 94 Cubic Inches**
- **Low Power - 8 Watts Typical at 28 VDC**
- **Three Selectable Video Inputs**
- **No Blurred Motion - Each Frame Separately Encoded**
- **User Programmable Video Parameters via EIA-232 Port**
- **Composite NTSC Color and PAL, Y/C Capabilities**
- **Transmits at Rates Up to 10 Mbps Over Any Digital Medium**

The encoder digitizes and compresses a standard analog NTSC color video signal and outputs a single, continuous, serial digital output signal representing the input picture clocked at any fixed rate up to 10 Mbps. A variety of standard transmission interfaces are available. Up to three separate video sources can be connected to the encoder. Each input can be selected (one at a time) via the EIA-232 control port. The encoder receives EIA-232 encoder control signal data as required, allowing for remote encoder setup using any DOS-based PC with terminal emulation. Setup includes user selectable adjustments for three levels of horizontal resolution (pixels/line), quantization level, crop mode, output bit rate, color, tint, system defaults, test patterns, and system status information. The 3-wire EIA-232 control port supports serial data baud rates of 300 to 9600; all external EIA-232 programming is held in EEPROM, and therefore, is retained upon power down. The ADVS® Advanced Digital Video Standard compression technique causes no blurring of the compressed picture upon the encoding and decoding of any type of moving objects within a given picture. Using this scheme, each and every video frame is digitized separately and completely.

A multiplexer provides inputs for asynchronous serial data, PCM data and clock, and an audio signal to be interspersed into the digitized video data stream.

ENC1000A94

ENC1000A94 Encoder Functional Block Diagram

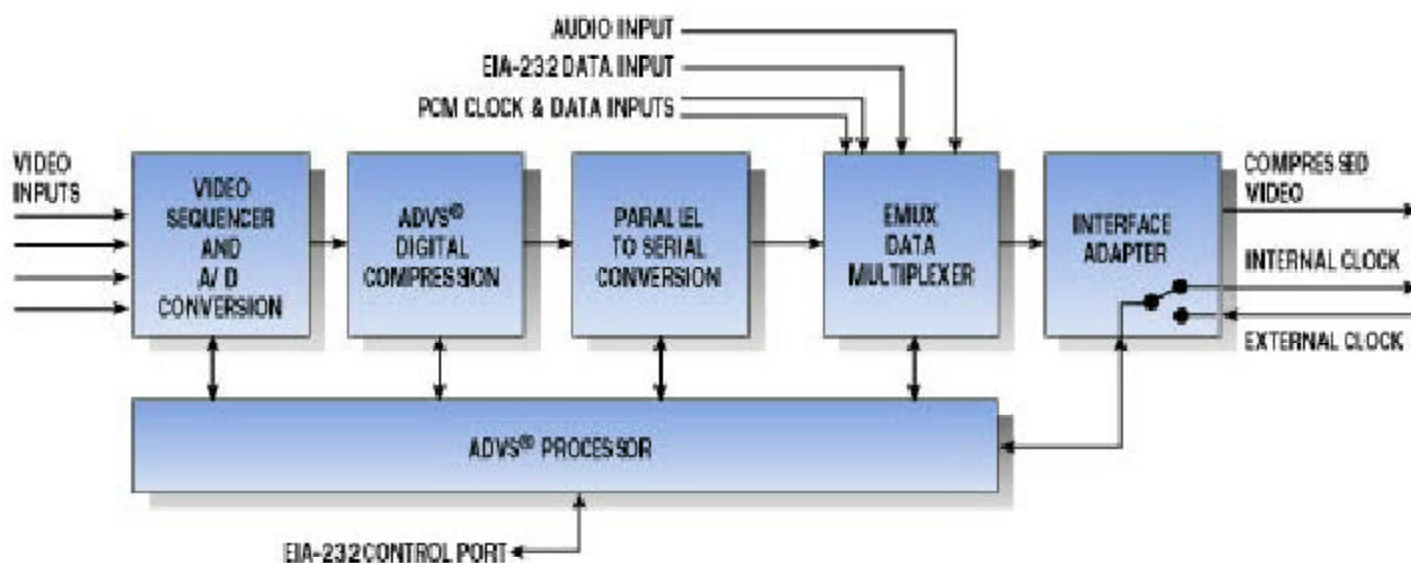

Standard Functions

FEATURE	DESCRIPTION
Video Inputs *	One of three inputs: NTSC or PAL, Composite or Y/C, 1 Vp-p, 75 ohms
Digital Data Outputs	NRZL clock and data, EIA-422A levels
Communications Port *	EIA-232C at 9600, 4800, 2400, 1200 or 300 baud
Data Multiplexer	
PCM input *	TTL, CMOS or EIA-422A selectable input levels, maximum data rate is 49% of total link frequency
Audio input *	300 Hz to 3000 Hz, 600 ohms, 1 Vp-p
EIA-232 multiplex input *	EIA-232C at 9600, 4800, 2400, 1200 or 300 baud
Resolution *	560, 280 or 140 pixels per line
Quantization *	240 steps
Cropping *	4 steps
Compression Standard	ADVS [®]
Internal Data Clock Output *	19 KHz to 13.3 Mbps in 38 steps
External Data Clock Input *	Any rate up to 10 Mbps
Interface Connector	TNC for each video input, 22-pin circular for power and control
Input Power	28 VDC \pm 20%
Power Consumption	350 mA maximum at 28 VDC
Dimensions	94 cubic inches, 7 in. x 4.5 in. x 3 in.
Weight	50 ounces
Operating Temperature Range	-40 to +85°C
MIL-STD-810 Testing	Consult factory for details
MIL-STD-461 Testing	Consult factory for details

Optional Functions

FEATURE	DESCRIPTION
Forward Error Correction *	Reed-Solomon correction at 12.3% overhead
Passlink [™] *	Volatile or non-volatile password storage

* Software Selectable

